



LJ DEVICE CO., LTD.

力臻股份有限公司

LJ DEVICE CO., LTD.

零件規格書 / 承認書

SPECIFICATION FOR APPROVAL

CUSTOMER : _____

DESCRIPTION : Cylindrical DC Motor

MODEL : FG-ZY1812LAA6FC

CUSTOMER PART NO : _____

APPROVED SIGNATURES

--	--	--	--

Rev	Date	Description	Designed	Checked	Approved
A	2024/6/24	Release		Po-Chen	

臺北市北投區吉利街 131 號 2 樓

2F, NO. 131, JILI ST., PEITOU, TAIPEI, TAIWAN, R.O.C.

TEL : 886-2-2827-0158 · FAX : 886-2-2827-0348

规格书内容/Contents

1. 适用范围/Scope	3/8
2. 标准使用条件/Standard Operating Condition	3/8
3. 结构/Construction)	4/8
4. 电气特性/Electrical Characteristics	5/8
5. 马达使用时注意事项/Motor General Instructions & Notes	6/8
6. 马达外形图/Motor Outline Drawing	7/8
7. 修改记录/Revision History	8/8



Dsgd 设计	Chkd 审核	Appd 批准	Part No: FG-ZY1812LAA6FC 料号				
			Document No 文件编号: FUGE-AA6FC Spec .Doc 规格书文档	Edition 版本: A	2/8		

1. 适用范围/Scope

NO.	專案: Items	規格: Specifications
1-1	額定電壓: Rated voltage	DC 4.0V 穩壓加於馬達連接線終端 4.0V DC CONSTANT between motor terminals.
1-2	工作電壓範圍: Operating Voltage Range	DC:2.0~6.0V穩壓加於馬達連接線終端 2.0V to 6.0V DC CONSTANT between motor terminals.
1-3	額定負載: Rated Load	負載: $\phi 18*4$ 疊片偏心輪 Load: $\phi 18*4$ Stacked eccentric wheel
1-4	回轉方向: Direction of Rotation	從輸出軸側觀察CW & CCW CW & CCW when viewed from output shaft side.
1-5	工作溫度/濕度範圍: Operating Temperature / Humidity Range	-10°C ~ +65°C / 30%~90%RH
1-6	儲存溫度/濕度範圍: Storage Temperature Range/Humidity range	-20°C ~+70°C/10%~90%RH
1-7	馬達安裝方向: Motor Position	出軸全方向 All direction of protruded shaft

2. 标准使用条件/Standard Operating Condition

NO:	專案: Items	規格: Specifications
2-1	馬達位置: Motor Position:	出力軸水準方向 Motor to be held, with shaft horizontaliy.
2-2	電源: Power Supply:	穩壓直流電源, 確保測量時無疑問 Regulated DC constant power supply.
2-3	旋轉方向: Direction of Rotation:	從出力軸看為順時針 CW when viewed from output shaft side
2-4	測試環境溫度與相對濕度: Environmental Temperature and Humidity:	所定規格的測試一般是在室溫10°C~30°C, 相對濕度為30%~95%的狀況. 若測試結果有疑慮時, 應以JIS標準測試條件為判定基準 (20°C \pm 2°C 65% \pm 5%RH) The test is made in principle at a temperature between +10°C and +30°C, and at relative humidity between 30% and 95%. If there is a problem with the results, it should be judged according to the JIS standard test conditions (+20° C \pm 2° C, 65% RH \pm 5%RH).

Dsgd 设计	Chkd 审核	Appd 批准	Part No: FG-ZY1812LAA6FC				
			料号				
			Document No 文件编号: FUGE-AA6FC	Edition 版本:			
			Spec .Doc 规格书文档	A	3/8		

3. 结构/Construction)

NO:	專案: Items	規格: Specifications
3-1	額定電壓無負載條件下電流: No Load Current:	最大40mA 40mA max
3-2	額定電壓無負載條件下轉速: No Load Speed:	3500rpm±10%
3-3	額定電壓額定負載條件下電流: Rated load Current:	最大55mA 55mA max
3-4	額定電壓額定負載條件下轉速: Rated Load Speed:	3000rpm±10%
3-5	始動電壓: Tumor-initiating voltage:	無負載狀態下最大 1.3 V 1.3 V (max.) under no load.
3-6	堵轉電流: Stall Current:	最大0.25A 堵轉不能超過3秒 The Maximum 0.25A
3-7	堵轉力矩: Stalling torque: 注: 扭力計測試, 堵死後保證馬達端子電壓達到4.0伏, 三秒內讀取數據, 同一電機不能連續測試超過三次 Note: Torque meter test, after blocking, ensure that the motor terminal voltage reaches 4.0 volts, and the data can be read in three seconds. The same motor cannot be tested more than three times in a row.	最小 10 g.cm The minimum 10 g.cm
3-8	絕緣電阻: Insulation Resistance:	馬達端子與金屬外殼之間的電阻最小1.0 MΩ /DC100V 1.0 Mohm (min.) (DC 100 V) between motor terminal and motor metal housing.
3-9	電氣噪音: Electrical Noise:	電機內裝有噪音抑制元件壓敏電阻器 The Motor is equipped with a noise suppression element varistors.
3-10	機械噪音: 在下列條件時: 電機施加額定電壓, 空載. 背景雜訊: 26 dB (max.) No load, rated voltage, with motor to be set and measured as below. Background noise: 26 dB max.	58dB max. JIS-A (RMS)

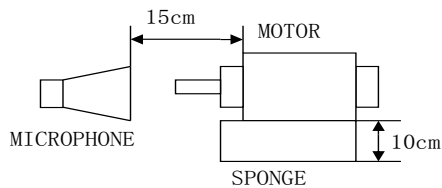



Dsgd 设计	Chkd 审核	Appd 批准	Part No: FG-ZY1812LAA6FC				
			料号				
			Document No 文件编号: FUGE-AA6FC	Edition 版本:			
			Spec .Doc 规格书文档	A	4/8		

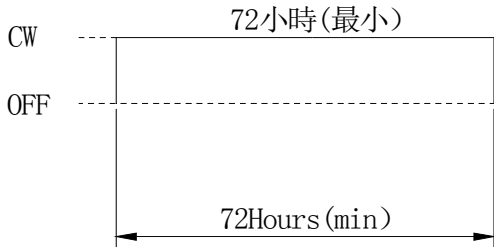

4. 电气特性/Electrical Characteristics

NO:	專案: Items	規格: Specifications
4-1	馬達安裝要求: Motor Position requirement:	外形安裝時按圖要求(附外觀圖) 電機應清潔無汙, 表面無碰傷變形及明顯刮傷痕, 鍍層無剝落, 緊配部件應牢固。 Install according to the drawing requirements (with the drawing) The motor shall be clean, the surface shall not be damaged or deformed, the coating shall not peel off, and the fastener shall be firm.
4-2	軸向間隙: Shaft End Play:	0.3mm MAX 0.3mm MAX
4-3	外觀: External Appearance :	參考馬達外觀圖: As per our Drawing No.
4-4	壽命: Life <試驗模式 (Test cycle) > CW 72小時(最小) OFF 	壽命時長: 72小時(min), 在下列條件下的總運行次數. 測試完成後滿足表4-5條件 電 壓 : 4.0V/DC 負 載 : 額定負載 壽命模式: 如左圖所示; CW連續運行 環 境 : 溫度20°C~30°C, 濕度45%~85% 72 Hours (min.) at the following condition.. Voltage: 4.0V DC constant Load: Rated Load Cycle: As shown on the left. Environment: 20°C~30°C, 45%~85%RH
4-5	判定基準: Life End (On life test, motor life is judged to come to an end, when)	轉速不大於初始值±30% The change in speed at the rated voltage exceeds +/-30%, or 電流不大於初始值±30% Current at the rated voltage versus the initial reading change measured before the life test is more than +/-30%, or 馬達判定顯然是無法使用時。 motor gets apparently recognized to be unusable.



Dsgd 设计	Chkd 审核	Appd 批准	Part No: FG-ZY1812LAA6FC 料号				
			Document No 文件编号: FUGE-AA6FC Spec .Doc 规格书文档	Edition 版本: A	5/8		

马达使用时注意事项 Motor General Instructions & Notes

1. 避免有害气体（例如：硫磺、瞬干胶、矽胶等）的产生场所和环境，以防止对马达外壳、端子及其它金属零件被氧化腐蚀，特别是工作环境使用了矽胶时，矽胶的挥发容易形成SiO₂造成马达换向器接点障碍，接触阻抗急剧增大，导致接触不良。
Avoid the place and environment where harmful gases (such as sulfur, instant dry adhesive, silica gel, etc.) are produced, so as to prevent the motor shell, terminals and other metal parts from being oxidized and corroded. Especially when silica gel is used in the working environment, the volatilization of silica gel is easy to form SiO₂, which causes the contact obstacle of motor commutator, and the contact impedance increases sharply, resulting in poor contact.
2. 马达端子焊接时应避免压入以免造成不良现象，焊接温度应在380℃内，时间2S内，防止端盖受热变形。
The motor terminal shall not be pressed in during welding to avoid adverse phenomena. The welding temperature shall be within 380 °C and the time shall be within 2s to prevent the end cover from thermal deformation.
3. 装配马达时，使用接著剂时，应避免流入轴承与轴心处，防止卡死不转动。
When the motor is assembled and the adhesive is used, it should be avoided to flow into the bearing and shaft center to prevent it from being stuck and not rotating
4. 马达通电后，轴心锁住时间与施加负荷，须注意若超过规格书之条件，可能导致漆包线、电刷烧毁情形发生。
Do not stall or overload the motor, this will cause motor to be overheated and some parts (For example, wire, brush...etc.) will be damaged.
5. 压入齿轮或滚轮及其他零件到轴上时，在另一侧，即后盖需用治具顶住支撑处，防止后盖变形与损坏并影响转子转动。 When pressing the gear or roller and other parts onto the shaft, on the other side, that is, the back cover should be held against the support with a jig to prevent the back cover from deformation and damage and
6. 马达使用时之环境温度应注意，尤其是高温高湿应避免，若超出规格条件，对马达之特性、寿命，将会有影响。
When using the motor, pay attention to the ambient temperature, especially the high temperature and high humidity. If it exceeds the specification conditions, it will affect the characteristics and service life of the motor.
7. 马达保存环境25℃±10%、湿度70%以下，马达在未开包装箱情况下，保存期为180天，并且马达品质符合制品规格书的要求。 The storage environment of the motor is 25 °C ± 10%, and the humidity is below 70%. The storage period of the motor is 180 days without opening the packing box, and the quality of the motor meets the requirements of the product specification.
8. 使用之螺丝锁紧马达时，螺丝与孔应平行，以防止螺纹损坏，若螺丝长度过长将对磁石造成破损，并影响转子运转。
When using the screw to lock the motor, the screw and the hole should be parallel to prevent thread damage. If the screw length is too long, it will damage the magnet and affect the rotor operation.
9. 若使用马达后有任何疑问或问题产生时，双方依承认之规格书检讨协议之。
In case of any doubt or problem after using the motor, both parties shall review the agreement according to the recognized specification.
10. 如需改善马达性能，在整体特性符合规格书内，敝司可对使用之部品、材料、治具、作业方法等作变更，但对重大变更时须知会贵司。
If it is necessary to improve the performance of the motor, our company can change the parts, materials, jigs, operation methods, etc. used within the overall characteristics in accordance with the specifications.
11. 本规格书其内容有疑问时，应由使用者纳入者双方检讨协议之。
In case of any doubt about the contents of this specification, both parties involved shall review the agreement.
12. 输入电压与马达时，工作电压不可超出规格书之电压范围，否则可能马达有烧毁之情形发生。
When inputting the voltage and motor, the working voltage shall not exceed the voltage range of the specification, otherwise the motor may burn out.
13. 紧固马达螺丝时，若使用电动起子，必须要有扭力调整器，其扭力控制在1.2kgf-cm (max) 内，同时在锁紧时，螺丝与孔必须在垂直方向受力。
When tightening the motor screws, if the electric driver is used, there must be a torque adjuster whose torque is controlled within 1.2kgf-cm (max). At the same time, when locking, the screws and holes must be
14. 当锁附螺丝时，其装配环境必须清洁干净，不能有磁性、塑胶粉末等异物，防止掉入孔内。
When attaching screws, the assembly environment must be clean and free of magnetic, plastic powder and other foreign matters to prevent falling into the hole.

以上所述之事项，若有任何疑问或未详细之处，请仅速与我方联系，我方将会乐意地协助您。

If you have any questions or have no details about the above matters, please contact us as soon as possible and we will be happy to assist you.

Dsgd 设计	Chkd 审核	Appd 批准			
			Document No 文件编号:FUGE-AA6FC Spec .Doc 规格书文档	Edition 版本: A	6/8

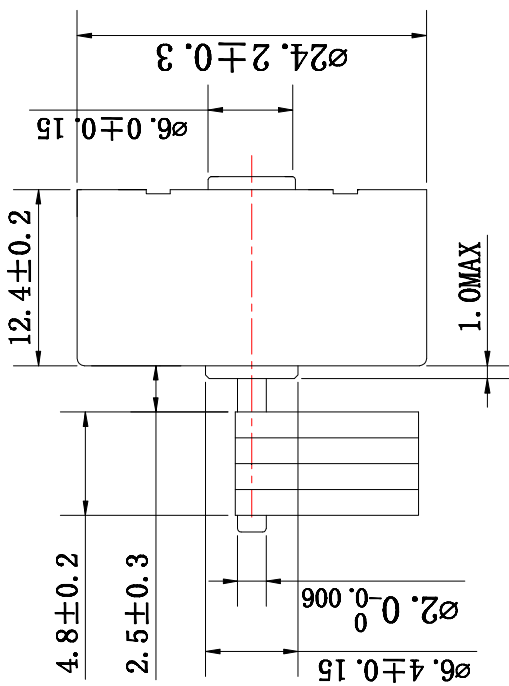
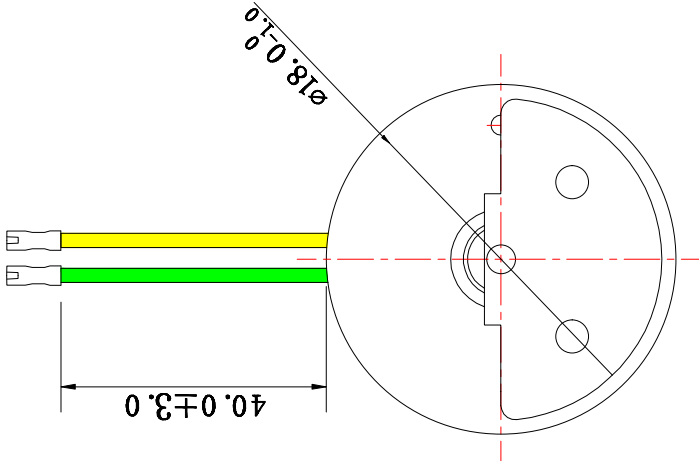
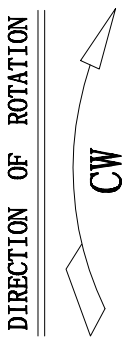
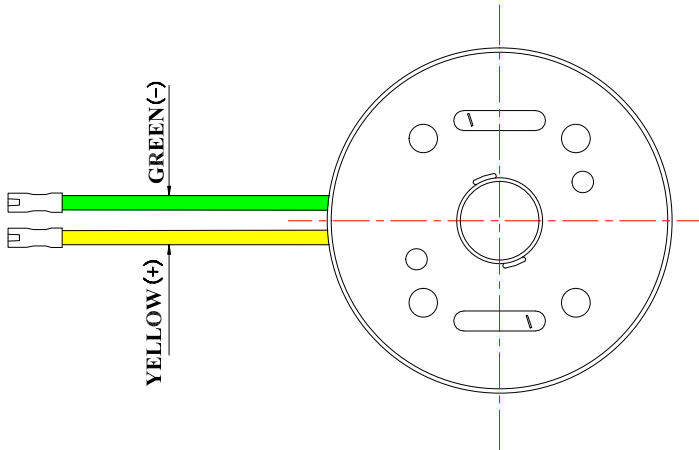

注記 (NOTES):

1. $7.0 \pm 0.5\text{mm}$ 只有在馬達軸位於右端極限位置時應用。
2. 軸向間隙範圍: 0.3mm MAX.
3. 未注尺寸公差: $\pm 0.2\text{mm.}$
4. 导线规格: AWG28 UL1571 Lead spec: AWG28 UL1571

标记	处数	分区	更改文件号
设计	张	2024.01.15	
校对	陈国栋	2024.01.15	
审核	徐旭	2024.01.15	
工艺			
FG-ZY1812LAA6FC			
外形图			
阶段标记		比例	
共 页		第 页	

