



LJ DEVICE CO., LTD.

力臻股份有限公司

LJ DEVICE CO., LTD.

零件規格書 / 承認書

SPECIFICATION FOR APPROVAL

CUSTOMER : _____

DESCRIPTION : _____ VIBRATOR _____

MODEL : _____ QRK-280DAVZL-23116 _____

CUSTOMER PART NO : _____

APPROVED SIGNATURES

--	--	--	--

Rev	Date	Description	Designed	Checked	Approved
A	2020/3/5	Release		Kevin	

臺北市北投區吉利街 131 號 2 樓

2F, NO. 131, JILI ST., PEITOU, TAIPEI, TAIWAN, R.O.C.

TEL : 886-2-2827-0158 · FAX : 886-2-2827-0348

重要提示 IMPORTANCE NOTES:

1. If there is any argument on motor performance and/or life, judgment is to be made base on this specification only.
 如对电机的性能和/或寿命有任何争议，仅基于此规格书作出判断。
2. Customer has the responsibility to ensure that the motor can satisfy the requirement of your application.
 客户方有责任确认该电机能满足您的申请要求。
3. In the event that an official specification is not present by customer; this document will specify the agreed technical specification with a performance curve data and outline drawing.
 如果贵公司未提供技术规格，该文件将详细叙述与贵公司商定的技术规格包括特性曲线数据和外形图。
4. Within the limitation to satisfy this specification, NL has the convenience to change the materials, sizes and shapes of components of the motor for the purpose of improving quality, and/or performance, and/or production efficiency.
 在满足规格的条件下，我司可以改变零件材料、尺寸及形状来改善品质，和/或性能，和/或生产效率。
5. After the receipt of this specification, customer should send a signed copy to NL prior order confirmation. NL regard it as the receipt of this specification acknowledged if customer fails to return the confirmation to us within the described period.
 收到此规格书后，贵司应于该规格书发出至正式订单之前将规格书副本签回以示贵司确认收到。如贵司未能在规定时间内签回副本，我司将认为贵司已收到并承认该规格书。

**更改记录
Revised Record**

Rev. 版次	Date 日期	Reason for change 更改原因	Designed 编制	Checked 审核	Approval 批准
A1	2019-07-29	增加寿命项	刘干	刘干	刘干
A2	2019-09-16	增加导线	尹根山	刘干	刘蕴
A3	2020-03-05	增加连接器	尹根山		刘蕴

1. 结构形式 Construction-form

PRODUCT SPECIFICATION

NO. 序号	Item 项目	Contents 内容
1.1	Motor construction 电机结构	Φ24.0*30.8 (mm) Round as the core of the DC motor 圆型马达Φ24.0*30.8 (mm) 的铁芯直流马达
1.2	Number of magnet poles 磁极极数	2-poles (Built -in magnetic ring) 两极(磁瓦内置)
1.3	Rectifying method 换向方式	Graphite Brush and commutator 石墨碳刷换向器装置

2. 标准使用条件 Standard operating condition

NO 序号	Item 项目	Specification 规格
2.1	Rated voltage 额定电压	Motor teminal voltage 3.5VDC 马达端子电压 3.5VDC
2.2	Rated load 额定负荷	Counter weight (sheet iron) R9.0*7.2mm 偏心轮 R9.0*7.2mm (铁片)
2.3	Rotation direction 旋转方向	CW (When viewed from output side with +ve voltage applied to +ve terminal) 顺时针方向旋转 (轴突视之, 电压正极接端子正极)
2.4	Motor position 摆放位置	Any position is available 任意位置均可
2.5	Voltage range for use 工作电压范围	DC2.0V~5.0V
2.6	Operating conditions 使用环境	-20℃~60℃ ordinary humidity常规湿度 15%~90%RH (no condensation of moisture/不凝露)
2.7	Storage conditions 贮存环境	-20℃~70℃ ordinary humidity常规湿度 15%~75%RH (no condensation of moisture/不凝露)

3. 产品测试环境条件 Environmental Test Conditions

NO. 序号	Item 项目	Environmental condition 测试环境条件
3.1	Temperature 温度	20±2℃
3.2	Humidity 湿度	60±5% RH
3.3	Motor Position 电机体位	Shaft Horizontal 轴伸水平
3.4	Power Supply 电源	Regulated DC power supply 恒定DC供给电源

NOTE: All data shall be based on the measurement under the temperature 20±2℃ and humidity 60±5% RH, however the range of temperature 5~35℃ and humidity 45~85%RH if there is no doubt about the judgment.

注: 所有的数据在温度 20±2℃, 湿度 60±5% RH的条件下测定。在对判定不发生异议时, 也可在温度 5~35℃, 湿度 45~85%RH的环境下测试。

PRODUCT SPECIFICATION

4. 机械特性 Mechanical Characteristic

NO. 序号	Item 项目	Measuring condition 测试条件	Specification 规格
4.1	Configuration 外观尺寸	Vernier caliper 游标卡尺	As specified in outline drawing 参考外形图
4.2	Weight 重量	Plate balance 0.1g 架盘天平 精度 0.1g	48.7g (Reference) 48.7g (参考)
4.3	Shaft end play 轴向间隙	Vernier caliper or Dial indicator 游标卡尺或百分表	(0.05- 0.50) mm

5. 电气性能 Electrical characteristics

NO. 序号	Item 项目	Measuring condition 测试条件	Specification 规格
5.1	No-Load current 空载电流	At Rated voltage and no load 额定电压及无负荷下测试	≤170mA
5.2	No-Load speed 空载转速		4700rpm±12 %
5.3	Rated Load 额定负荷	At Rated voltage and rated load 额定电压及标准负荷下测试	Counter weight (sheet iron) R9.0*7.2mm 偏心轮 R9.0*7.2mm (铁片)
5.4	Rated current 额定电流		≤290mA
5.5	Rated speed 额定转速		4200rpm.±12 %
5.6	Starting Voltage 始动电压	Connect the voltage into the ends 将电压直接接在马达端子之间	1.5VDC max
5.7	Insulation resistance 绝缘电阻	At DC 100V, measured between housing case and terminal. 在 100V 直流电压下, 电机引线与外壳间测量	≥ 10MΩ

6. 拒收 REJECTS

Motor that do not meet with the specifications mentioned above or which are apparently judged as faulty due to poor workmanship.

电机不能满足规格要求, 或判定存在明显工艺缺陷。

7. 注意事项 CAUTIONS

1) 环境影响 ENVIRONMENTAL EFFECT

If has including xi a kind of material and the compound, easy to adsorb in motor's commutator, the electronics brush and other, after the motor in the electrical energy influence, will decompose will be sio2, sic and other sideline products, these materials will cause the commutator and electronics brush's

PRODUCT SPECIFICATION

contact resistance increase rapidly, therefore, motor when and will use together including xi a kind of material and the compound, will want the special attention to create the motor part's damage, especially when the use will enter including xi a kind of viscose and the packing material the motor group your firm department and the product, please note verifies when will use and the hardening, will not produce mist of the volatile, will injure to motor's performance and the life, When selects the cyanide and the sulfide viscose, also wants the special attention to create the motor part's corrosion.

如有含矽类物质及化合物, 易吸附于马达的换向器, 电刷及其他部品, 经马达中之电能影响, 会分解为 SiO_2 , SiC 及其他副产品, 这些物质都会使换向器与电刷的接触电阻急速增加, 因此, 马达在与含矽类物质及化合物一起使用时, 要特别注意造成马达部件的损伤, 尤其在使用含矽类粘胶及密封材料将马达组入贵公司部品及产品时, 请注意查明在使用及硬化时, 不会产生挥发性之雾气, 伤害到马达的性能及寿命, 在选用氰化物及硫化物的粘胶时, 也要特别注意造成马达部件的腐蚀。

2) 移动电机 **MOVE YOUR MOTOR**

Please deal with the motors gently, you should make use of the outer case as possible as you can.
拿电机时, 应轻拿轻放, 应尽可能地利用外壳部分

Do not press the product with more than 0.5 kgf or drop it. It can cause the transformation of performance or external appearance.

请勿将其跌落或加以超过 5 公斤的压力。否则会引起电机的外部形态和电气特性的改变

3) 储存 **STORAGE**

Storage temperature: $-20^{\circ}\text{C}\sim 70^{\circ}\text{C}$

Storage relative humidity: 15%~75%

Avoids storing in high temperature、high humidity or corrosive gas environment.

储存温度: $-20^{\circ}\text{C}\sim 70^{\circ}\text{C}$

储存湿度: 15%RH~90%RH

避免放置在高温、潮湿及有腐蚀性气体的环境中。

4) 使用电机 **HANDLING OF MOTOR**

-to handle and hold the vibration motor case softly.

-do not bring magnetized object near or contact with the surface of motor to avoid of performance being deteriorated.

-pay attention to the handling and working environments of motor, because such objects as iron powder if attracted by motor magnet, will cause noise characteristic deterioration, thus reducing the reliability.

小心拿取、使用。

避免放置在磁性物体附近或接触其表面, 这将影响其功效。

注意操作环境, 尤其注意若铁粉被磁铁吸附, 将出现噪音问题, 降低使用寿命

Please do not operate or store the motor near magnet or magnetic devices.

请勿靠近磁体或有磁场的装置存放或运行电机

5) 安装您的电机 **MOUNTING YOUR MOTOR:**

Some NL motors provide tapped holes in the motor housing for you to use to mount your motor. Please take care not to use screws so long that they can interfere with components inside the motor.

部分力臻都在电机定子上提供了安装孔用来安装您的电机, 请注意不要使用过长的螺钉以避免损坏电机内部元件。

Bearing bosses are also used for mounting motors. Please avoid excessive clamping forces on these areas.
轴承固定座也是用来安装您的电机的, 对此安装区域请避免过度用力。

PRODUCT SPECIFICATION

When mounting your motor, please try not to completely close or around the motor, motor should be set aside space for heat dissipation

在安装电机时，请尽量不要完全紧贴或包住电机，应为电机留出散热空间。

It is preferable not to use features on the motor such as ventilation holes for location means. It is possible that these features may change as new or modified tooling is used in the future.

最好不要利用电机表面的特征来固定电机，例如：通风孔。这样将可能会改变这些特征。

Any ventilation holes in the motor should not become blocked in your product without consultation with NLO

如未咨询我司，装入贵司产品中的电机上的任何通风孔都不可以堵死。

If adhesives are to be used to mount you motor care must be taken to avoid any adhesive getting into the bearing areas.

如果使用粘合剂安装电机，必须注意粘合剂不能进入轴承区域。

6) 电机接线 CONNECTION YOUR MOTOR:

Assembles in the process, has work which the motor welds, please by all means must cover the motor all birthplace perforation and the gap, in avoids the tin dregs, the welding flux, material motors and so on smog enters, especially when welds motor's ties or the post, wants the special attention weld period not to be bigger than for 2 seconds, otherwise the wire rod or the post peripheral revertex can have phenomena and so on distortion, other preventive measure also needs to consummate as far as possible, in order to avoid creates motor's harm, please by all means must on motor's ties or the post residual materials and so on tin dregs and welding flux eliminate, otherwise when electric conduction the motor can have exceptionally and the harm condition.

装配过程中，有马达焊接的工作，请务必将马达所有贯穿孔及间隙都覆盖好，避免锡渣，助焊剂，烟雾等物质马达进入内部，尤其在焊接马达的连接线或端子时，要特别注意焊接时间不得大于 2 秒，否则线材或端子周边的塑胶会产生变形等现象，其他的预防措施也要尽量完善，以免造成马达的损害，请务必将马达的连接线或端子上残留的锡渣及助焊剂等物质清除，否则在导电时马达会有异常及损害状况。

7) 电机联轴 COUPLING YOUR MOTOR:

If you intend to couple a gear or a fan or some other item to your motor shaft during assembly, always remember that unusual radial and axial loads transmitted to the motor from the coupling during operation of the motor can have serious effects on the life of the bearings. If you have any concerns about this please consult with NL

装配过程中，如果电机出轴端欲衔接齿轮、风叶等其它配件，请牢记，如果安装不当，电机运转时一种非正常的径向或轴向负荷将通过连接加载到电机，这种负荷将对轴承寿命造成严重影响。如果您对此有任何担心，请咨询我司。

8) 过负荷 OVERLOADS:

Small high power motors are subject to very fast temperature rises. Take care not to apply excessive voltage to the motor or to operate it at stall or near stall for prolonged periods without first consulting with NL

体积小、功率高的电机通常温升高；如未咨询我司，使用时请注意不能加过高的电压，不能运行在堵转或接近堵转状态过长时间。

9) 危险环境 HAZARDOUS ENVIRONMENTS:

The degree of protection against corrosion on NL motors is satisfactory only for normal environments. There are small sections of the housing in which some bare metal is exposed and is susceptible to

PRODUCT SPECIFICATION

corrosion. It is advisable not to store or use motors in corrosive environment without consultation with NL

我司电机在正常环境中的抗腐蚀能力是符合要求的,但机壳上有少许区域存在的裸露金属对腐蚀比较敏感,因此未经咨询请不要在腐蚀环境中储存或使用电机,

10) 其它说明 OTHERS:

The motor may cause slight electronic noise due to the contact between brush and commutator.

当换向器和碳刷接触时,电机会发出轻微的电噪音

The motor has a strong magnet so please be aware that it has a magnetic force on the surface of the bracket.

电机内部有很强力的磁铁,所以机壳表面也存在磁力

It is allowable to have a few spots on the surface or edge of case.

外壳表面或边缘有少许斑点是允许的

11) ALWAYS REMEMBER that NL has a substantial team of application engineers dedicated to the solution of problems on our motors that used in new products or new applications. We are proud of our good working relationship with our customers and we will be most pleased if we can assist you to find a solution to any problem that you may encounter.

请谨记: NL股份有限公司拥有一支实质性的团队,应用工程师致力于解决我们的电机

在新的产品或新的应用中出现的问题,我们乐意与您建立良好的合作关系,我们乐意为您解决使用中遇到的各种问题。

8. 附件 ATTACHMENT

- 1) 电机外形图 Motor Outline Drawing
- 2) 性能曲线-CW转向 Performance Curve – CW direction

————— END —————

Sample No: GG-19062601/4954 Customer 艾登 Date: 2020-3-6

Model: QRK-280DAVZL-23116 Efficiency

----- Power output

NOTE: Performance (in an ambient temperature of 25-30°C)
Motor tested rapidly to prevent significant temperature rise.

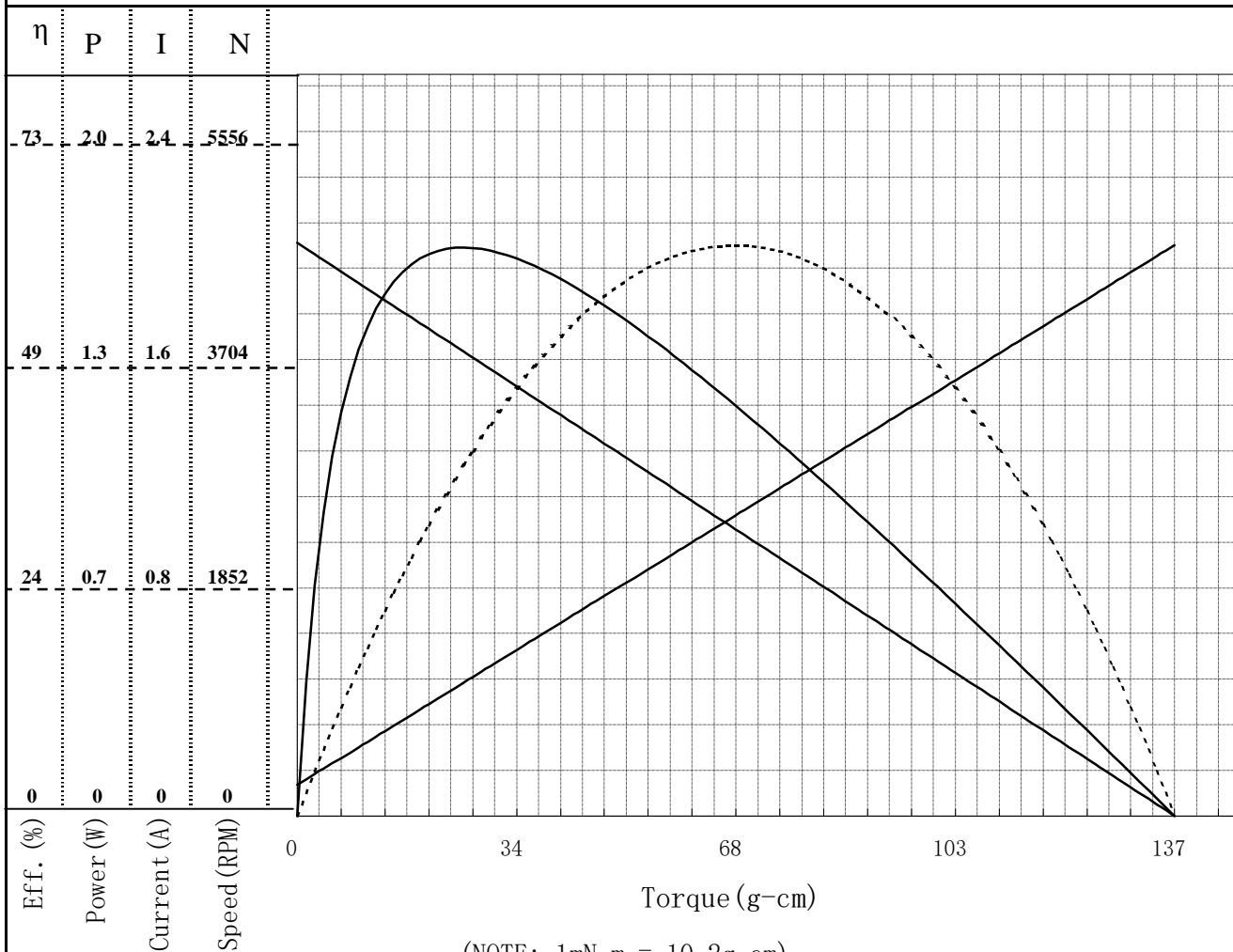

(NOTE: 1mN-m = 10.2g-cm)

Constant voltage : **3.5** V_{DC}
Direction: **CW**
At No Load
Speed: **4650** rpm
Current: **0.11** A
At stall (Extrapolated)
Torque: **137.0** g-cm
Current: **2.02** A
At maximum efficiency
Efficiency: **60.8** %
Torque: **26.0** g-cm
Speed: **3767** rpm
Current: **0.47** A
Output: **1.00** W
At maximum Power output
Output: **1.63** W
Torque: **68.5** g-cm
Speed: **2325** rpm
Current: **1.07** A

Issued by QA Reliability Testing Center

COMPUTER PRINT-OUT
NOMINAL MOTOR CURVES

Performance and characteristics are measured based on limited motor samples only

Prepared by:尹根山

Checked by:

Approved by:刘蕴

DIRECTION OF ROTATION
旋转方向

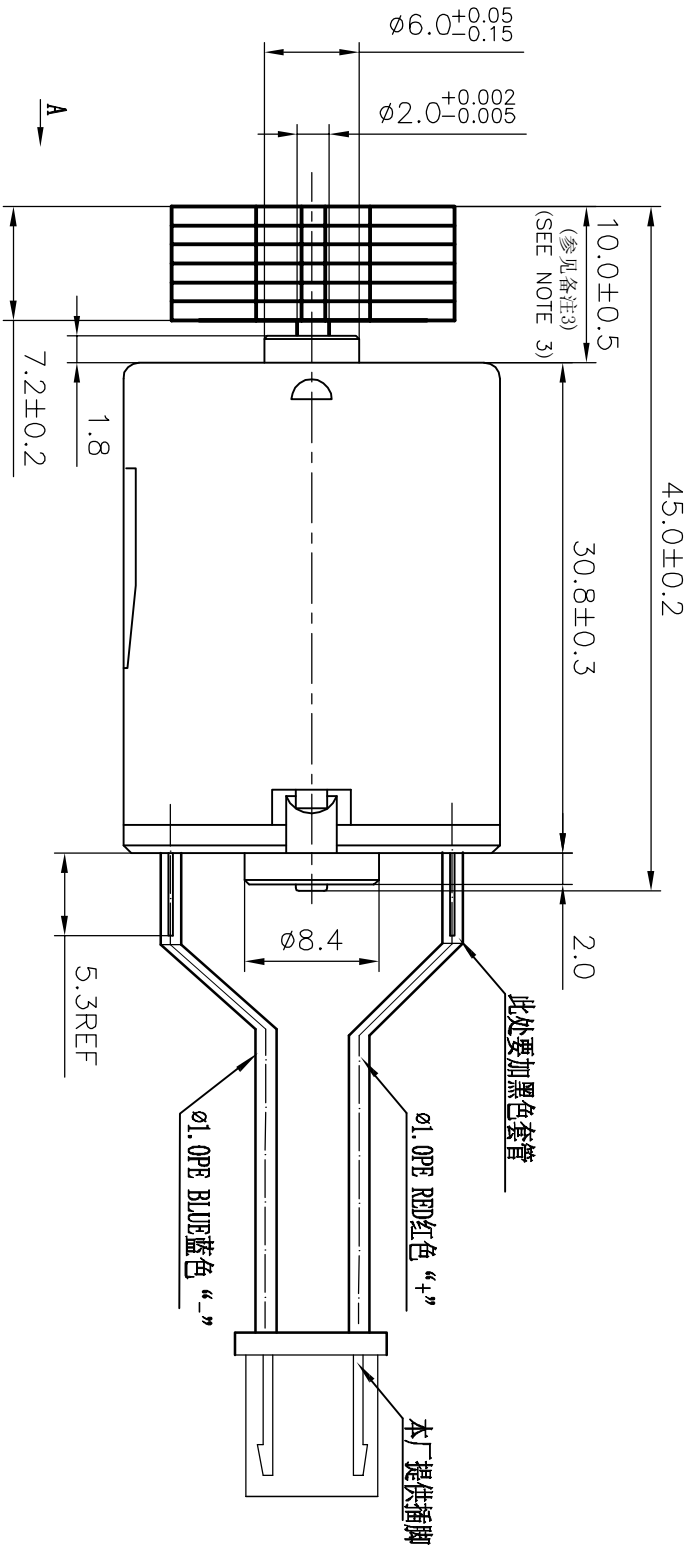
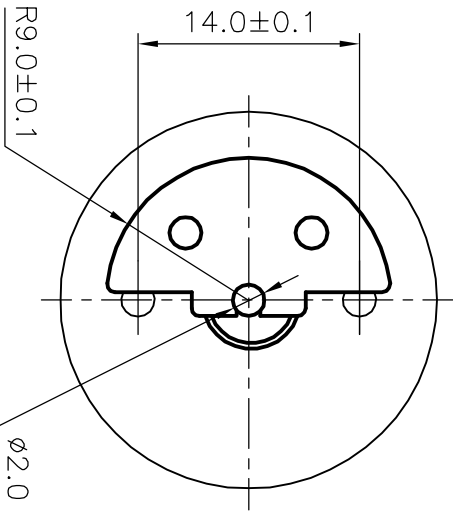

NOTES:

备注:

- 1、DIRECTION OF ROTATION IS C.W.
WHEN VIEWED FROM THE OUTPUT SHAFT;
马达顺时针方向旋转,轴突视之;
- 2、END PLAY: 0.05—0.50;
马达虚位:0.05-0.50;
- 3、THE DIMENSION IS THE LENGTH WHEN THE
SHAFT IS PUSHED INTO "A" DIRECTION.
轴顶向"A"方向的长度;
- 4、DIMENSION IS IN "MM".
以上尺寸以毫米为单位.

SYMBOL	SIGNATURE	DATE	DC MOTOR OUTLINE		TITLE	
DESIGNED	尹根山	20-03-06			DRAWING NO. 0	
CHECKED					GC-19062601/4954	
TECHNIQUE					PAGE	/
DRAWN						
APPROVED	刘蕴	20-03-06			