

力臻股份有限公司
LJ DEVICE CO., LTD.

零件規格書 / 承認書
SPECIFICATION FOR APPROVAL

CUSTOMER : _____

DESCRIPTION : _____ **Motor** _____

MODEL : _____ **TFF-N20VA-10140** _____

CUSTOMER PART NO : _____

APPROVED SIGNATURES

--	--	--	--

Rev	Date	Description	Designed	Checked	Approved
A	2018/10/11	Release		Maya	

臺北市北投區吉利街 131 號 2 樓

2F, NO. 131, JILI ST., PEITOU, TAIPEI, TAIWAN, R.O.C.

TEL : 886-2-2827-0158 · FAX : 886-2-2827-0348



SPEC No: TFM-201810005

樣品規格

PAGES: 1/4

DATE: 2018-10-11

SPECIFICATIONS

EDITION: A1

1. 標準操作條件: Standard Operating Conditions

No.	項目: Items	規格: Specifications
1-1	額定電壓: Rated Voltage	DC 3.0V 穩壓加於馬達連接線終端 3.0V DC constant between motor terminals
1-2	工作電壓範圍: Operating Voltage Range	DC: 1.5~4.5V 穩壓加於馬達連接線終端 1.5~4.5V DC constant between motor terminals
1-3	額定負載: Rated Load	Φ10.0*6.0 銅振子 10.0*6.0 Eccentric laminated oscillator
1-4	旋轉方向: Direction of Rotation	順時針 CW
1-5	工作溫度/濕度範圍: Operating Temperature Range/Humidity range	-10°C ~ +50°C / 5%~85%RH
1-6	儲存溫度: Storage Temperature Range	-40°C ~ +80°C
1-7	馬達安裝方向: Motor Position	任意方向 All directions of protruded shaft

2. 標準測試條件: Standard Test Conditions

No.	項目: Items	規格: Specifications
2-1	馬達位置: Motor Position	軸芯水平旋轉 Motor to be held with shaft horizontally
2-2	電源: Power Source	穩壓直流電源, 確保測量時無疑問 Regulated power supply which assures unquestionable measurement
2-3	旋轉方向: Direction of Rotation:	從出力軸端看為順時針 CW when view from output shaft side
2-4	測試環境溫度與相對濕度: Environmental Temperature and Humidity	所定規格的測試一般是在室溫 10°C~30°C, 相對濕度為 30%~85% 的狀況. 若測試結果有疑慮時, 應以 JIS 標準測試條件為判定基準 (20°C ± 2°C, 65% ± 5%RH) The test is made in principle at a temperature between 10°C to 30°C, and at a relative humidity between 30% to 85%. If the test is questionable, it shall be judged from the test made at JIS Standard Testing Condition (20°C ± 2°C, 65% ± 5%RH)



SPEC No: TFM-201810005
DATE: 2018-10-11

樣品規格
SPECIFICATIONS

PAGES: 2/4
EDITION: A1

3. 電氣特性: Electrical Characteristics

No.	項目:Items	規格:Specifications
3-3	額定電壓額定負載條件下電流: Rated load Current	最大350mA 350mA max
3-4	額定電壓額定負載條件下轉速: Rated Load Speed	6700rpm±15%
3-5	始動電壓: Tumor-initiating voltage	負載状态下最大1.5V 1.5V(max) Load condition
3-6	堵轉電流: Stall Current	最大850mA(不超過3秒) 850mA max(No more than 3 seconds)
3-7	絕緣電阻: Insulation Resistance	馬達端子與金屬外殼之間的電阻最小1.0 MΩ /DC100V 1.0MΩ min. (DC100V)

4. 電機的機械特性: Mechanical Characteristics

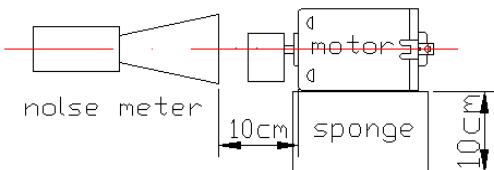
No.	項目:Items	規格:Specifications
4-1	馬達安裝要求: Motor Position requirement	外形安裝時按圖要求(附外觀圖)電機應清潔無污,表面無碰傷變形及明顯刮傷痕,鍍層無剝落,緊配部件應牢固。 As per the dimensional drawing No remarkable deformation or superficial defects to be observed by visual check. Fastened parts to be fixed firmly
4-2	軸向間隙: Shaft End Play	0.05~0.15mm
4-3	機械噪音: Mechanical Noise	下列條件下65dB. 無負載, JIS-A等級下額定電壓(RMS), 按如下測量位置安裝馬達, 背景噪音<26.7dB 65dB(max.) with following condition. No load, related voltage (RMS) on JIS-A scale With motor to be set and measured as below Background noise: 26.7dB max 
4-4	馬達外觀: External Appearance	參考馬達外觀圖 See Outline Drawing



有限公司

® 89J=79 7C' ž LTD.

使用 有限公司馬達一般注意事項

General Instructions for Use of motors DO'S and DON'TS to keep your motors in ordertian

- 一、 如有含矽類物質及化合物，易吸附於馬達的換向器、電刷或其他部品，經馬達中之電能影響，會分解為SiO₂、SiC及其他副產品，這些物質都會使換向器與電刷的接觸電阻急速增加。因此馬達在與含矽類物質及化合物一起使用時，要特別小心造成馬達部件的損傷。尤其在使用含矽類黏膠及密封材料，將馬達組入貴公司部品及產品時，請注意查明在使用及硬化時，不會產生揮發性之霧氣，傷害到馬達的特性及壽命。在選用氧化物、硫化物的黏膠時，也要特別小心造成馬達部件的腐蝕。
If silicon materials, which contain low molecular silicon compound adhere to the motor's commutator, brush of other parts, then upon rectification of the electric energy the silicon breaks down into SiO₂, SiC and other constituents which produce a rapid increase in the contact resistance between the commutator and brush. therefore great care should be taken when silicon material is used in a unit and check well at the same time that such binding agents or sealing materials are not generating gases of detrimental nature, whether used for motor mounting or applied during your product assemblies. care must be taken for an optimum selection, especially when using those of cyanic adhesive and sulfur gas.
- 二、 當組裝貴公司部品及產品時，請特別注意，勿使任何黏膠接觸到馬達的軸承，或讓黏膠流入馬達本體之內。
When mounting your motors by means of binding agents, DON'T flow any adhesive to the Bearings nor intrusion into the motors.
- 三、 經由軸心，軸向壓入馬達的力量會對馬達的壽命有極大的影響，例如滑輪齒輪、風扇頁等。在有軸向壓力的狀況下，馬達的壽命應在貴公司部品及產品中實際操作環境下測試而得之數據為準。當軸向壓力過大時，應考慮用機械方式固定軸心。
Axial thrust on the output shaft could have an adverse effect on the motor life i.e... as is produced by worm gears, fans etc, check the service life expected under the actual operating conditions by testing the motors installed in your application products .for heavy thrust loads consider using something mechanical to retain the shaft end.
- 四、 在某些使用狀況，驅動馬達所使用的電源供應器之內電阻也會影響馬達的壽命。如馬達之驅動為低電壓之電源，而內電阻過大是會導致馬達不能達到預期的效果與特性。相反的情況，如馬達之驅動為高電壓之電源時，或常切換不同之驅動電壓時，內電阻過小時，會使馬達的壽命縮短。在周遭溫度與一般標準室溫有偏差時，尤其是過高或過低溫時，請特別注意電源及其內電阻的改變。
There are occasions when the internal resistance of the motor driving power source (which contains an electrical circuit) can influence the life span of the motor. in instances where there is a low input of voltage to the motor, the internal resistance of The Power source is large which may well result in an inferior motor after a short time, conversely in instances where high cyclic voltage are applied, this internal resistance is small and the motor life span is shortened. when the temperature deviates from the normal room temperature as is the case in low and high temperature situations, please note the conditions.
- 五、 當有相當的軸心徑向的壓力，如軸心上加裝偏心輪，或操作環境有相當的震動時，馬達的壽命會受到嚴重的影響。在此情況，馬達的壽命必須由實際狀況操作的數據為依據。
Motor life may be affected adversely by heavy radial load such as produced by rotating eccentric cams, etc., and also by vibration given from outside. Do check over such negative factors by testing the motors to the actual operating conditions in your application products.
- 六、 如果貴公司裝置吾司馬達或組立貴司產品時，所用設備、機械會發出超音波時，請特別注意，超音波有可能對馬達內部零件造成損害。
If when mounting the motor and assembling the unit, equipment which emits ultrasonic waves is used there is a danger that some of the internal parts of the motor might be damaged so please take care,
- 七、 請勿將馬達儲存於高溫或高濕度的環境。請勿將馬達儲存於有腐蝕性氣體的環境。這些環境都會使馬達損壞，無法正常使用。
DON'T store motors under environmental conditions of high temperature and extreme humidity.
DON'T keep them also in an atmosphere where corrosive gas may be present, as it may result in malfunction.
- 八、 週遭環境及操作溫度會對馬達的特性與壽命有所影響。請特別留心使用此馬達時，週遭可能有的高溫或高濕度的環境。
Ambient and operating temperatures exert an affect more or less on motor performance and Do pay particular attention to the surroundings when it is hot and damp
- 九、 如果貴司需要將齒輪、滑輪等零件壓入吾司馬達的軸心時，請一定要適當的、正確的支撐軸心的另一端或馬達的後蓋及其凸起。
When press fitting a pulley, gear etc., onto the motor output shaft, always support the shaft from the other end on its retaining metal pad in a proper and correct way.
- 十、 如果貴公司組立貴司產品時，有焊接的工作，請務必將馬達上所有的貫穿孔、間隙都覆蓋好，不使焊渣、助焊劑、煙霧等有機會進入馬達。尤其在焊接馬達的連接線或端子時，要特別注意，焊接要盡快完成，否則，線材或端子週遭的塑膠會產生變形。其他預防措施也要盡量完善，以免造成馬達的損害。請務必將馬達的連接線或端子上殘留的助焊劑清除，否則在導電時會有異常狀況及損害。
When soldering, BE SURE to finish your work quickly so as not to develop plastic deformation around the motor terminals nor to give them any forced bend or inward depression. in doing deformation- special care must be taken not to allow solder debris and flux to spatter into motors and precaution measures should be taken if necessary, by covering up all the nearby holes and apertures. Any motors having snap in terminals must also be attended carefully so as not to get flux in along the terminals, as it may cause failure in electrical conduction.
- 十一、 請務必注意，任何狀況下都不可將馬達的軸心鎖死。當馬達軸心鎖死時，會產生高熱，不但馬達本身會損壞，也會使週遭易燃物釀成災害。
DON'T leave motor shaft locked while power is applied, as even a short time lock up may cause excessive heat build up resulting in burning damage to the motor depending on its specifications.

若需要更詳細的資料，請與我們的業務員或授權的代理商直接聯絡。

For more information, please contact us directly or through our sales and representative offices.

版本:A

DIMENSION	X	X.X	X.XX	X.XXX
PRECISION	±0.2	±0.1	±0.05	±0.005

DIRECTION OF ROTATION

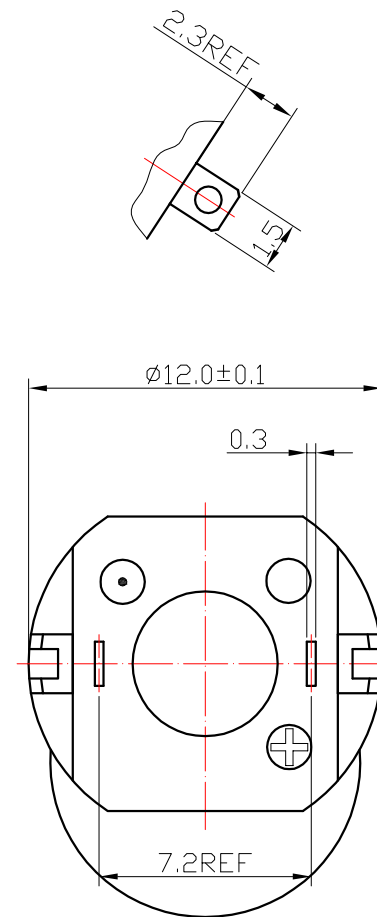
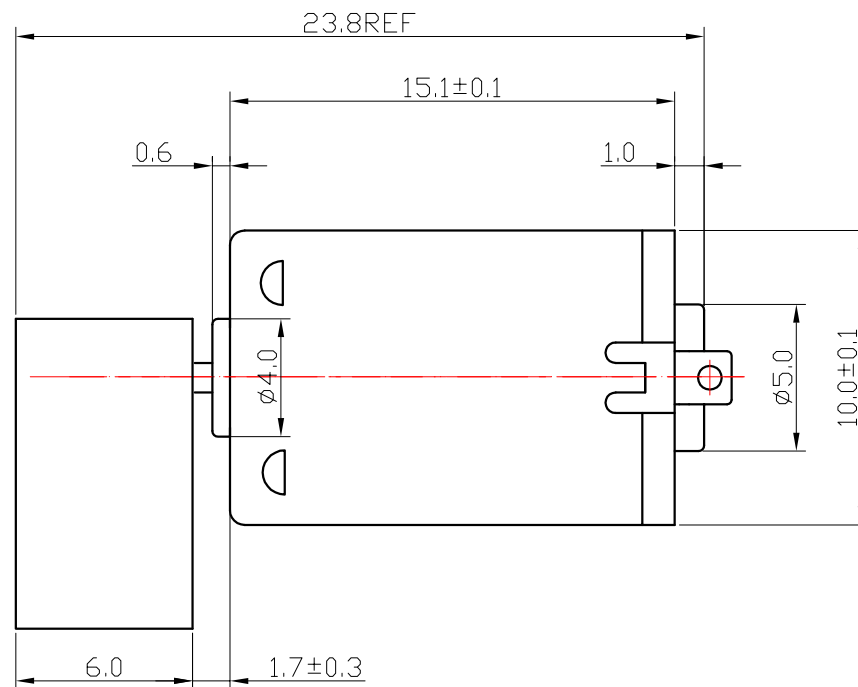
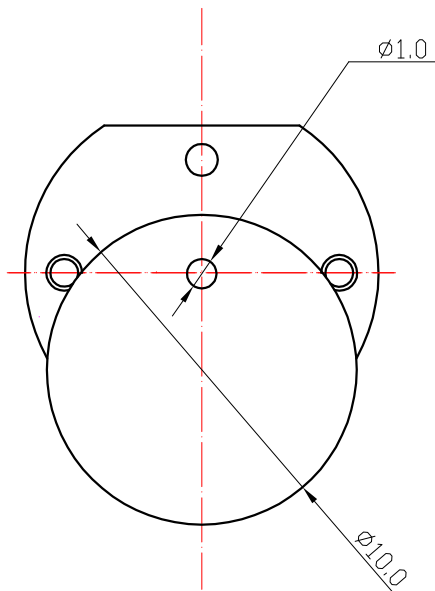

技术要求

1. 电机轴向间隙0~0.15mm;
2. 端子焊接温度350° C, 2s max;
3. 当 (+) 端子接电源时, 电机转向如箭头所示。

REVIEW	DATE	<p style="font-size: 24px; margin: 0;">有限公司</p>		
VERIFY	DATE			
CHECK	DATE	TITLE		
DESIGN	DATE	TFF-N20VA-10140 外形图		
		ITEM		REV 2
		SCALE 2:1	MATERIAL	PAGE 1
				1