



LJ DEVICE CO., LTD.

力臻股份有限公司

LJ DEVICE CO., LTD.

零件規格書 / 承認書

SPECIFICATION FOR APPROVAL

CUSTOMER : _____

DESCRIPTION : _____ VIBRATOR _____

MODEL : _____ :: !M* %\$&- (&?% 5 _____

CUSTOMER PART NO : _____

APPROVED SIGNATURES

--	--	--	--

Rev	Date	Description	Designed	Checked	Approved
A	201, /1%&+	Release		Dc!7\ Yb	

臺北市北投區吉利街 131 號 2 樓

2F, NO. 131, JILI ST., PEITOU, TAIPEI, TAIWAN, R.O.C.

TEL : 886-2-2827-0158 · FAX : 886-2-2827-0348

规格书内容/Contents

1、适用范围/ General Scope	3/9
2、使用条件/ Operating Conditions	3/9
3、测定条件/ Measuring Conditions	3/9
4、机械要求/ Mechanical Specifications	3/9
5、性能特征/Performance and characteristics	4/9
6、可靠性/Reliability	5/9
7、要求/Requirements	6/9
8、使用时注意事项/ attentions	6/9
9、包装/Packaging	7/9
10、外形图/Outline Drawing	8/9
11、修改记录 / REVISION HISTORY	9/9

型号/ Part No.	HI / [8324; 64MB8C
--------------	---------------------

1. 适用范围/ General Scope
 本说明书适用于圆筒式永磁直流电机 HI / [8324; 64MB8C 型
 This specification applies to cylindrical permanent-magnetic motors DC model
 HI / [8324; 64MB8C0"
2. 使用条件/Operating Conditions

	项目/Item	规格/Specifications	条件·备注/Conditions & Remarks
2-1	额定电压 Rated voltage	1.3 V DC	
2-2	额定负荷 Rated load	振子 Vibration weight	见 10. 外形图 As specified in 10. Outline Drawing
2-3	旋转方向 Rotation	CW.CCW(clockwise or anticlockwise)	
2-4	马达位置 Motor position	全方位 All position	
2-5	使用电压范围 Operating voltage	0.9~1.6V DC	
2-6	使用环境 Operating environment	-30 ~ 70℃, 常湿 /Ordinary Humidity:65±20%RH	无水气凝结 No condensation of moisture
2-7	保存环境 Storage environment	-40 ~ 80℃, 常湿 /Ordinary Humidity:65±20%RH	无水气凝结 No condensation of moisture

3. 测定条件/Measuring Conditions

	项目/Item	规格/Specifications	条件·备注/ Conditions & Remarks
3-1	温度 Temperature	20±2℃	
3-2	湿度 Humidity	(63%~67%) RH	
3-3	位置 Motor position	轴向水平 Motor shaft horizontal	将马达固定在试验台上 Lock the motor in a test fixture

标准测试条件为温度 20℃，湿度 65%。如无疑异，也可在温度 5~35℃、湿度 45~85%的条件下测试。马达测试时，放置方向为轴向水平。/The measurement at 20℃ & 65%RH is standard. If the judgment is not questionable, recognize measurement at 5℃ to 35℃ & relative humidity 45% to 85%. Direction of motor is shaft horizontal.

4. 机械要求/Mechanical Specifications

	项目/Item	规格/Specifications	条件·备注/ Conditions & Remarks
4-1	结构 Configuration	见 10. 外形图 As specified in 10. Outline Drawing	Outline drawing No: HI / [8324; 64MB8C
4-2	外观 Appearance	不含有机械损坏及不适当的浸蚀等。 There shall be no evidence of mechanical damage and shall not have inadequate corrosion and so on	目测（容许范围根据样品外形） Visual examination(allowable extent is based on boundary sample)
4-3	轴向间隙 Shaft end play	0.1mm~0.3mm	
4-4	振子固定力 Holding strength of vibration weight	49N (5kgf) Min	

5. 性能特征/Performance and characteristics

项目/Item	规格/ Specifications	条件·备注/ Conditions & Remarks
5-1 额定转速 Rated speed	5500±2000rpm	在额定电压和额定负载（振子）下。 At rated voltage and rated load (Counterweight).
5-2 额定电流 Rated current	70 mA Max	
5-3 堵转电流 Stall current	105 mA Max	在额定电压下。 At rated voltage
5-4 起动电压 Starting voltage	0.9V DC Max	在额定负载（振子）下电枢的任意位置。 At rated load (Counterweight) any position of rotor.
5-5 绝缘电阻 Insulation resistance	1MΩ Min	在 100V 直流下，端子和机壳间 At DC 100V between Terminal and case.
5-6 端子阻抗 Terminal resistance	15Ω (±20%)	在 20℃ 下 At 20℃

5-7 机械噪音 Mechanical noise	50dB(A)Max	
---------------------------------	------------	--

在额定电压、额定负载（振子）下
背景噪音：不大于 28dB.A 计权
测试仪器：B&k
夹具重量：700g
At rated voltage and rated load (Counterweight).
Back ground noise 28dB(A) Max
Measuring instruments: B&k
Weight of jig:700g

5-7

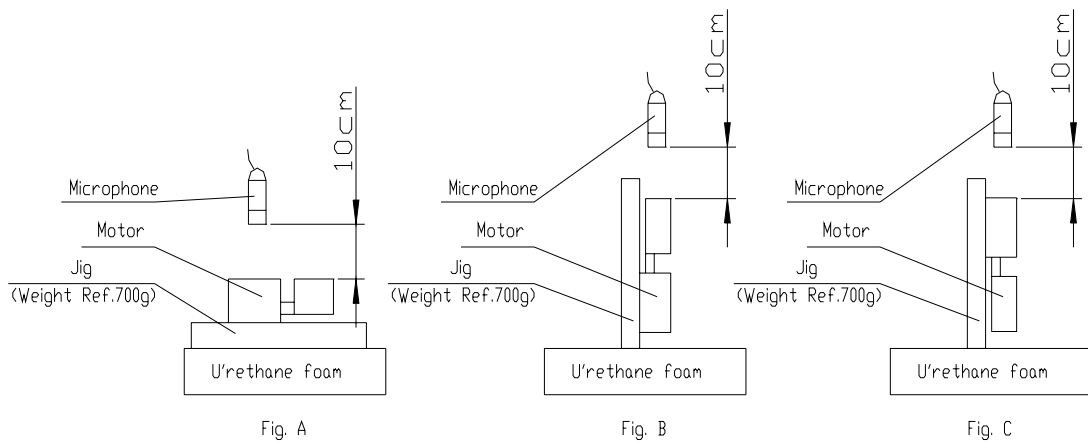

2018.33.49		说明书/Specification			编号/		代码/ code:0		5/9	
6. 可靠性/Reliability										
项目/Item		规格/ Specifications						判定标准/Judgment		
6-1	寿命 Life time							<p>在常温常湿下放置 2h 后，马达应符合项 7-1 的要求。 After 2 hours exposure in ordinary temperature and humidity, Motors shall be approved as specified in item 7-1.</p>		
		位置 Position	电压 Volt	负荷 Load	温度 Temp	湿度 Humi	寿命 Life			
		轴水平 Horizon	额定 Rated	重量 Weight 振子	20°C	65%	200,000 Cycles			
6-2	低温放置 Low temp exposure	温度 /Temperature: $-40\pm 2^{\circ}\text{C}$ 时间 /Time: 96h						<p>在常温常湿下放置 2h 后，马达应符合项 7-2 的要求。 After 2 hours exposure in ordinary temperature and humidity, Motors shall be approved as specified in item 7-2.</p>		
6-3	高温放置 High temp. Exposure	温度 /Temperature: $60\pm 2^{\circ}\text{C}$ 时间 /Time: 96h								
6-4	湿度放置 Humidity exposure	温度 /Temperature: $40\pm 2^{\circ}\text{C}$ 湿度 /Humidity: 90~95%RH 放置时间 /Exposure time: 96h 无水气凝结/No condensation of moisture								
6-5	振动 Vibration	全振幅 /Displacement : 1.5mm (p-p) 频率 /Frequency: 10 ~ 55Hz 周期 /Period: 1min 范围内 10~55~10Hz /20 Minutes log sweep10~55~10Hz 方向 /Direction: x, y, z 时间 /Time: 每 2h/Every 2 hours						<p>测试结果应符合项 7-2 的要求。 After the test motors shall be approved as specified in item 7-2.</p>		
6-6	自然跌落 Free fall	试验状态/Test state:将马达固定在约 75 克（包括马达本身）的物体上，落向水泥地面。 Set the motor to the approximately 75g (include the motor) weight of block drop the motor on the concrete floor. 高度 /Height: 1.5m 方向 /Direction: $\pm x, \pm y, \pm z$ 次数 /Number of times:每个方向 2 次 / Twice 2 each						<p>测试结果应符合项 7-2 的要求。 After the test motors shall be approved as specified in item 7-2.</p>		
6-7	热冲击 Heat shock test	试验循环 /Test cycle :20 cycles 						<p>在常温常湿下放置 2h 后，马达应符合项 7-2 的要求。 After 2 hours exposure in ordinary temperature and humidity, Motors shall be approved as specified in item 7-2.</p>		

(Z6S) 圆柱马达包装
Packaging drawing of Z6S cylindrical motor

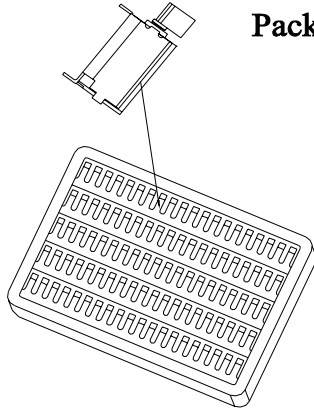

100PCS (1 tray) × 10

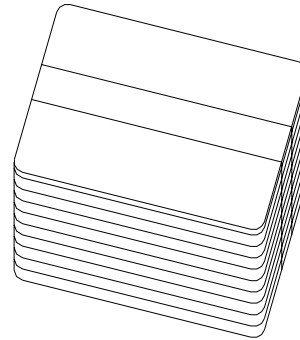

1000PCS (1 bundle) × 6

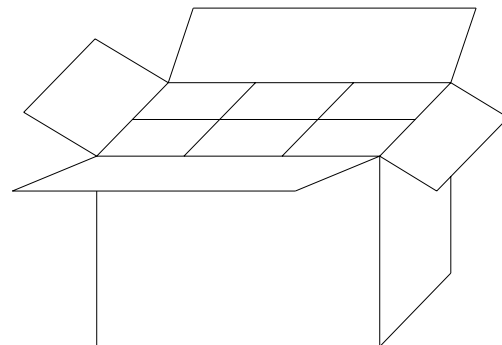

包装试验要求

1. 标准

- (1) 整箱重量小于等于9kg的, 跌落高度设定为75cm.
(2) 整箱重量大于9kg但小于等于23kg的, 跌落高度设定为60cm.

2. 试验方法:

跌落要求为六面三棱一角。

- (1) 六面: 先从最大两面跌, 然后是中间大小的两面, 最后跌最小的两面, 一共六次。
(2) 三棱: 指任选三条同一角的棱, 跌落秩序: 最长棱, 中间长度, 最短的, 一共三次。
(3) 一角: 指上一步三条棱所组成的角, 跌落一次。

3. 判定基准

经过跌落试验后, 产品外观、性能无不良。

Package Test Requirement:

1. Criteria

- (1) The weight of the whole carton less than 9kg, the dropping height is 75cm.
(2) The weight of the whole carton more than 9kg and less than 23kg, the dropping height is 60cm.

2. Test Methods:

Dropping requirement is 6 faces, 3 arris, 1 angle.

- (1) 6 faces: First dropping with two biggest faces, then dropping with another two middle faces, at last dropping with two smallest faces, once per face, total 6 faces.
(2) 3 arris: Choose any 3 arris which make up of the same the angle, the dropping sequence is the longest arris, middle arris, shortest arris. Total 3 times.
(3) 1 angle: Point to the angle which is made up with the 3 arris in the above step. Dropping for 1 time.

3. Judgement Criterion

After drop test, no evidence of damage on the appearance and performance.

Remarks:

- 1000PCS/CTN: 24cm × 17.5cm × 27.5cm
2000PCS/CTN: 34cm × 24cm × 27.5cm
4000PCS/CTN: 47cm × 34cm × 27.5cm
6000PCS/CTN: 54cm × 47cm × 27.5cm

OPP TAPE

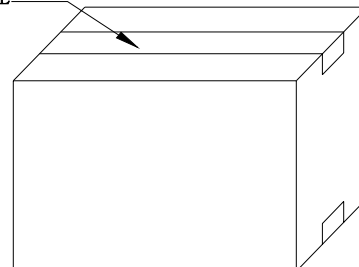

10. 外形图/Outline Drawing

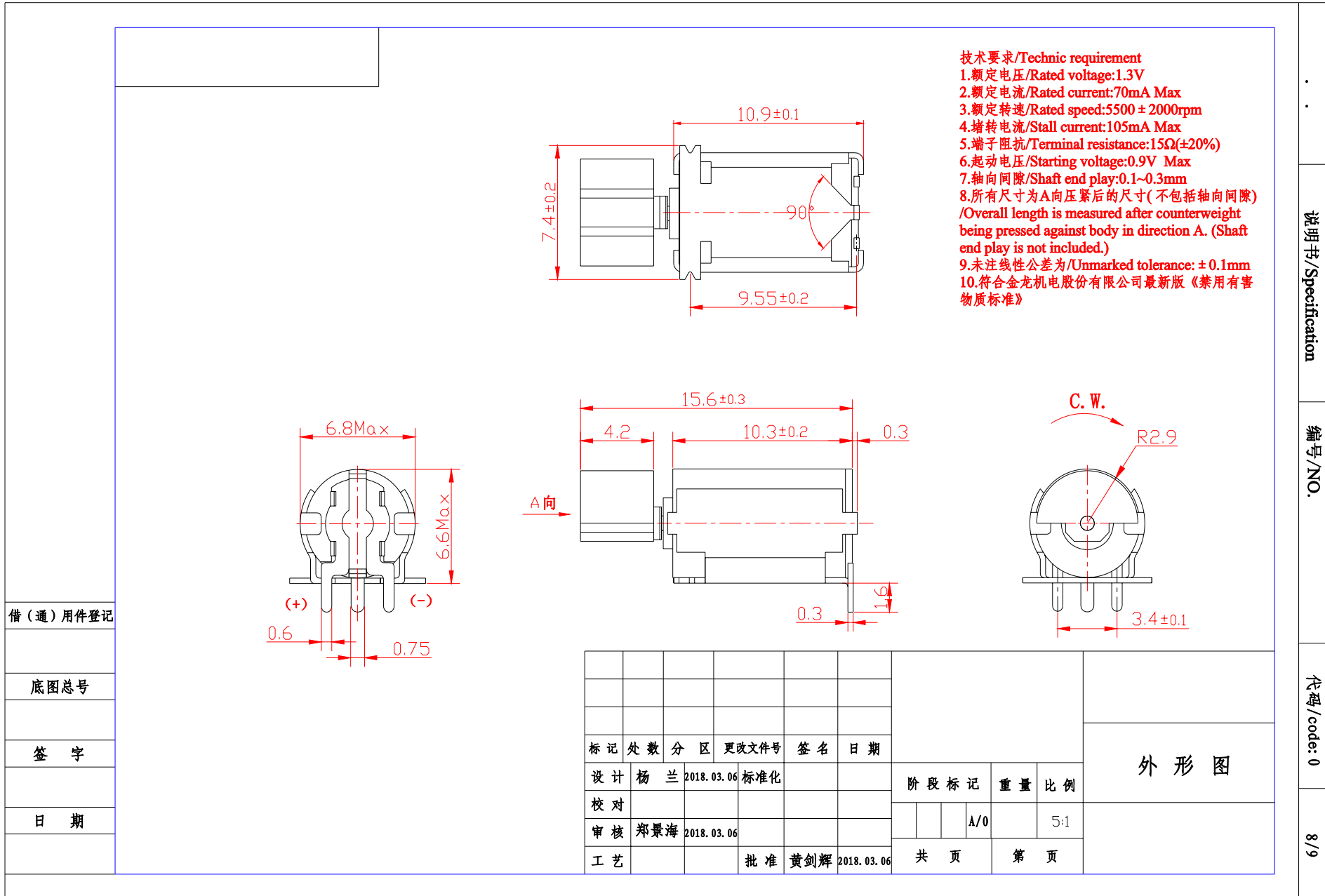

说明书/Specification

编号/NO.

代码/code: 0

8/9

