



LJ DEVICE CO., LTD.

力臻股份有限公司

LJ DEVICE CO., LTD.

零件規格書 / 承認書

SPECIFICATION FOR APPROVAL

CUSTOMER : _____

DESCRIPTION : φ 10*12mm,R5.5*3mm , DC3.0V

MODEL : L10CL-02M3V

CUSTOMER PART NO : _____

APPROVED SIGNATURES

--	--	--	--

Rev	Date	Description	Designed	Checked	Approved
A	2004/10/19	Release		Kevin	
B	2012/10/15	Reduce speed		Kevin	

臺北市北投區吉利街 131 號 2 樓

2F, NO. 131, JILI ST., PEITOU, TAIPEI, TAIWAN, R.O.C.

TEL : 886-2-2827-0158 · FAX : 886-2-2827-0348

**SPECIFICATION****技術指導書**

VIBRATION MOTOR	MODEL NO.:	DATE: 2012/10/15	
振動馬達	L10CL-02M3V	PAGE: 1/6	REV: B

1. CONSTRUCTION FORM 結構形式:

NO. 序號	ITEM 項目	CONTENTS 內容
1-1	MOTOR CONSTRUCTION 馬達結構	10 CYLINDRICAL DC CORELESS MOTOR 直徑為 10mm 的空心杯振動馬達
1-2	NUMBER OF PHASES 相數	3-PHASE (CONNECTION) 三相
1-3	NUMBER OF MAGNET POLES 磁網極數	2-POLES (INNER MAGNET TYPE) 兩極 (磁網內置)
1-4	COIL CONSTRUCTION 線圈結構	CYLINDRICAL MOVING COIL 圓柱型線圈
1-5	RECTIFYING METHOD 換向方式	PRECIOUS BRUSH AND COMMUTATOR 電刷換向器裝置

2. STANDARD OPERATING CONDITION 標準運行條件:

NO. 序號	ITEM 編號	SPECIFICATION 規格
2-1	RATED VOLTAGE 額定電壓	DC 3.0V
2-2	RETED LOAD 額定負荷	VIBRATION WEIGHT (AS SPECIFIED IN OUTLINE DRAWING) 偏心鍾(尺寸參考相關圖紙)
2-3	ROTATION DIRECTION 回轉方向	CW(CLOCKWISE) FROM THE COUNTER WEIGHT 順時針方向
2-4	MOTOR POSITION 擺放位置	ANY POSITION IS AVAILABLE 任何位置都可以
2-5	VOLTAGE RANGE FOR USE 工作電壓範圍	DC 2.2~4.2V
2-6	WORKING TEMPERATURE RANGE 工作溫度範圍	-20°C ~60°C 10~90% (RELATIVE HUMIDITY/相對濕度)

**SPECIFICATION****技術指導書**

VIBRATION MOTOR 振動馬達	MODEL NO.: L10CL-02M3V	DATE: 2012/10/15	
		PAGE: 2/6	REV: B

3.ELECTRICAL CHARACTERISTICS 電氣性能:

NO. 序號	ITEM 編號	MEASURING CONDITION 測試條件	SPECIFICATION 制品規格
3-1	RATED SPEED 額定轉速	AT RATED VOLTAGE AND RATED LOAD 額定電壓及負荷下測試	4000 rpm~6400 rpm
3-2	RATED CURRENT 額定電流	AT RATED VOLTAGE AND RATED LOAD 額定電壓及負荷下測試	100mA max
3-3	STALL CURRENT 堵轉電流	AT RATED VOLTAGE AND SHAFT LOCK 額定電壓及鎖定電機軸條件下測試	140mA max
3-4	STARTING VOLTAGE 起動電壓	AT RATED LOAD AND STEP VOLTAGE 額定負荷及電壓直投法條件下測試	2.2V max
3-5	STARTING TORQUE 起動扭矩	AT RATED VOLTAGE AND SHAFT LOCK 額定電壓及鎖定電機軸條件下測試	0.4G*CM min
3-6	TERMINAL RESISTANCE 電樞電阻	MEASURE BETWEEN TERMINALS 端子間測量	32Ω±20%
3-7	INSULATION RESISTANCE 絕緣電阻	100V DC BETWEEN LEAD WIRE AND CASE 在導線與馬達機身之間提供 100V DC	10 MΩ min
3-8	MECHANICAL NOISE 機械噪音	AT RATED VOLTAGE AND RATED LOAD BACK GROUND NOISE: -28 dB (A) MAX 額定電壓及負荷下測試背景噪音不超過負 28 分貝	-45dB(A) max
		<p>The diagram illustrates the mechanical noise measurement setup. It shows a motor mounted on a test block. A microphone is positioned 10 cm away from the motor. The microphone is connected to a sound level meter.</p>	

ADD: MEASURING CONDITION 測試條件

1.: MEASURING TEMPERATURE: 10-35 °C 測試溫度: 10-35 °C

2.: MEASURING RELATIVE HUMIDITY: 45% - 75% 測試相對濕度: 45% - 75%

**SPECIFICATION****技術指導書**

VIBRATION MOTOR	MODEL NO.:	DATE: 2012/10/15
振動馬達	L10CL-02M3V	PAGE: 3/6 REV: B

4. MECHANICAL CHARACTERISTICS 機械特徵:

NO. 序號	ITEM 項目	MEASURING CONDITION 測試條件	SPECIFICATION 規格
4-1	CONFIGURATION 外觀尺寸	VERNIER CALIPER 油標卡尺	AS SPECIFIED IN OUTLINE DRAWING 參考相關外形圖紙
4-2	APPEARANCE 外觀	VISUAL EXAMINATION 目測	SHOULD BE NO EVIDENCE OF MECHANICAL DAMAGE, CRACK, RUST, AND STAIN 不得有明顯的機械擦痕, 裂縫, 銹跡及污點
4-3	WEIGHT 重量	BALANCE 天平	7±0.3G (APPROX) 7±0.3 克 (左右)
4-4	SHAFT END PLAY 軸向間隙	DISTANCE OF AXIAL PLAY ON SHAFT 軸向間隙	0.3mm max

5. RELIABILITY TEST 可靠性試驗:

SHOULD BE SATISFIED WITH THE REQUIREMENTS OF TABLE 1 AFTER
TEST. 通過以下測試後應滿足表 1 的規格需求.

TABLE 1: REQUIREMENTS ITEM 表一: 評估項

NO. 序號	ITEM 項目	SPECIFICATION 規格
5-1	RATED CURRENT 額定電流	INITIAL DATA: ±30% MAX 最大不超過初始始值的±30%
5-2	RATED SPEED 額定轉速	INITIAL DATA: ±30% MAX 最大不超過初始始值的±30%
5-3	STARTING VOLTAGE 起動電壓	2.2V DC MAX 最大不超過 2.2V DC
5-4	OTHERS 其它	1) SHOULD NOT FALL IN STARTING 2) SHOULD NOT BE UNUSUAL MECHANICAL NOISE 1)正常啟動 2)無異常噪音

**SPECIFICATION****技術指導書**

VIBRATION MOTOR	MODEL NO.:	DATE: 2012/10/15
振動馬達	L10CL-02M3V	PAGE: 4/6 REV: B

6. RELIABILITY TEST ITEMS 可靠性測試項目

NO. 序號	ITEM 項目	TEST CONDITION 測試條件
6-1	LIFE TEST 壽命測試	1) VOLTAGE: 3.0V 測試電壓: 3.0 伏 2) LOAD: DOUNTER WEIGHT 負荷: 偏心鍾 3) TEMPERATURE: 20±2°C 溫度: 20±2°C 4) RELATIVE HUMIDITY: 65±5% 相對濕度: 65±5% 秒 TEST MODE: 20,000 TIMES AFTER OPERATION CONDITIONS AS SEC. ON 8 SEC. OFF 52 SEC. 測試方式: 開 8 秒, 關 52 秒, 循環 20,000 次
6-2	HIGH TEMPERATURE EXPOSURE 高溫放置	EXPOSURE TO 80°C FOR 96 HOURS THEN RETURN TO ORDINARY TEMPERATURE AND HUMIDITY FOR 2 HOURS. 在溫度 80°C 條件下放置 96 小時後在正常溫度和濕度條件下放置 2 小時
6-3	LOW TEMPERATURE EXPOSURE 低溫放置	EXPOSURE TO -40°C FOR 96 HOURS, THEN RETURN TO ORDINARY TEMPERATURE AND HUMIDITY FOR 2 HOURS. 在溫度 -40°C 條件下放置 96 小時後在正常溫度和濕度條件下放置 2 小時
6-4	HUMIDITY TEST 濕度測試	EXPOSURE TO 60±2°C, 90±5% RH (RELATIVE HUMIDITY) FOR 96 HOURS, THEN RETURN TO ORDINARY TEMPERATURE AND HUMIDITY FOR 2 HOURS. 在溫度 60±2°C, RH90±5% (相對濕度) 條件下放置 96 小時後在正常溫度條件下放置 2 小時
6-5	HEAT CYCLE TEST 熱循環測試	EXPOSURE TO HEAT TEST CONDITION UNDERLINE FOR 5 TIMES, THEN RETURN TO ORDINARY TEMPERATURE AND HUMIDITY FOR 24 HOURS. 在下圖測試條件下循環 5 次後在正常溫度和濕度條件下放置 24 小時
6-6	VIBRATION TEST 振動測試	VIBRATE WITH 1.5 MM, 10HZ-55HZ-10HZ PER MINUTE, X-Y-Z EACH DIRECTION FOR 30 MINUTES AT STANDARD PACKING CONDITION. 正常包裝情況下, 每分鐘 10HZ-55HZ-10HZ 循環, 振幅 1.5mm 條件下沿 XYZ 三個方向各振動 30 分鐘
6-7	DROP TEST 落體測試	SET THE MOTOR TO THE APPROXIMATELY 100 G (INCLUDING THE MOTOR) WEIGH OF BLOCK, FREE DROP DIRECTION 3 TIME ON THE CONCRETE FOLLR 馬達連正常包裝約 100g, 從 1.5 米的高度自由落落體到水泥地面, X-Y-Z 三個方向各 3 次.

**SPECIFICATION****技術指導書**

VIBRATION MOTOR	MODEL NO.:	DATE: 2012/10/15	
振動馬達	L10CL-02M3V	PAGE: 5/6	REV: B

7. CAUTIONS 注意事項：

7-1 ALLOWABLE RANGE FOR USE PAY ATTENTION TO VOLTAGE AND CURRENT RANGES FOR USE, AND USE THE VIBRATION MOTOR IN THE CONDITION ACCORDANCE WITH THIS SPECIFICATIONS, OR THE LIFE AND PERFROMANCE SHOULD BE CONSIDERABLY REDUCED.

工作範圍

注意電壓及電流的使用範圍，並且在本指標書規定情況下使用馬達，否則將相應降低馬達的使用壽命和性能

7-2 STORAGE

STORAGE TEMPERATURE: -40°C ~ + 85°C

STORAGE RALATIVE HUMIDITY: 10-90%

AVOIDS STORING IN HIGH TEMPERATURE, HIGH HUMIDITY OR CORROSIVE GAS ENVIRONMENT.

儲存

儲存溫度: -40°C ~ + 85°C

儲存濕度: 10-90%

避免放置在高溫，潮濕及有腐蝕性氣體的環境中

7-3 SOLDERING CONDITIONS**焊接溫度條件**

250°C --- WITHIN 5 SECONDS 五秒內

350°C --- WITHIN 3 SECONDS 三秒內

7-4 HANDLING OF MOTOR

- TO HANDLE AND HOLD THE VIBRATION MOTOR CASE SOFTLY.
- DO NOT BRING A MAGNETIZED OBJECT NEAR OR CONTACT WITH THE SURFACE OF MOTOR TO AVOID OF PERFORMANCE BEING DETERIORATED.
- PAY ATTENTION MUST TO THE HANDLING AND WORKING ENVIROMENTS OF MOTOR, BECAUSE SUCH OBJECTS AS IRON POWDER IF ATTRACTED BY MOTOR MAGNET, WILL CAUSE NOISE CHARACTERISTIC DETERIORATION, THUS REDUCING THE RELIABILITY.

使用馬達

- 小心拿取，使用
- 避免放置在磁性物體附近或接觸其表面，這將影響其功效
- 注意操作環境，尤其注意若鐵粉被磁鐵吸附，將出現噪音問題，降低使用壽命。



SPECIFICATION

技術指導書

VIBRATION MOTOR

MODEL NO.:

DATE: 2012/10/15

振動馬達

L10CL-02M3V

PAGE: 6/6

REV: B

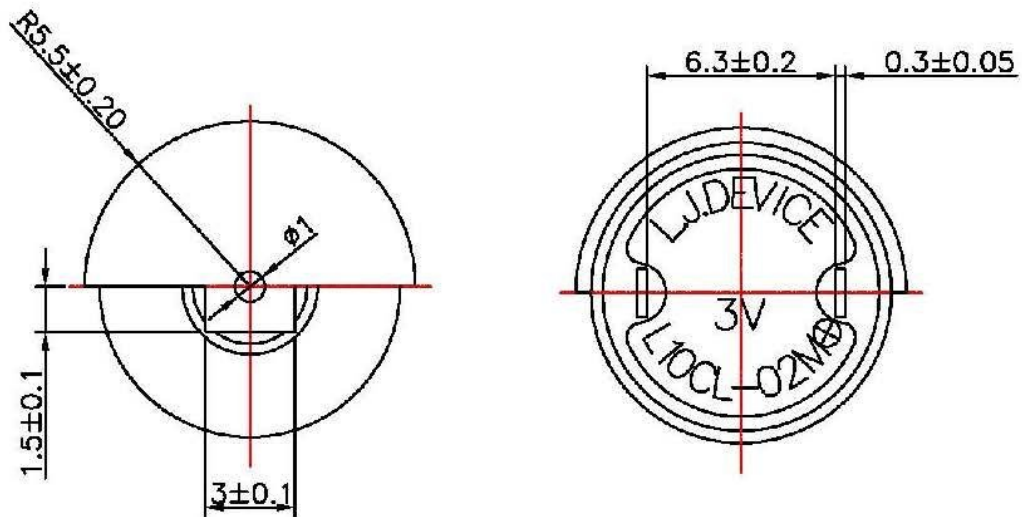
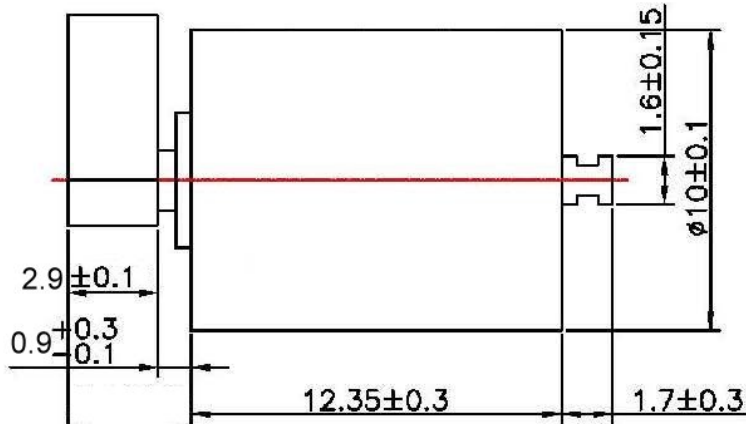

PS:1.擺錘材質:錫合金 2.擺錘重量: $2.51 \pm 0.2g$